

**e-FIRE MODULE INSTALLATION GUIDE**

**Module Testing**

You can test e-FIRE modules off the car using these diagrams. Once connected to a fully charged battery, turn the distributor drive by hand in the direction of engine rotation, looking for faint flashes at the test light. Note: You can use a 12 volt battery and test light without problem on e-FIRE 6v positive modules, but you must use the correct polarity. Red wires are always negative ground and white are positive. Check continuity from the module plate to the cap clip. If there is no continuity, attach the clip to the module plate mounting screw. If, at any point, the module is wired incorrectly, supplied with excess voltage (over 14v) or the polarity reversed, it may fail and void your warranty.

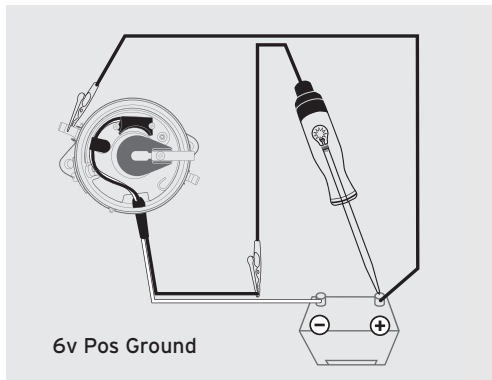
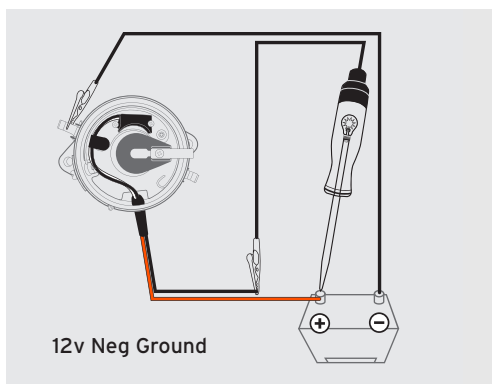

**Limited Warranty**

All Stromberg products receive numerous checks and tests to ensure optimum quality and performance. Stromberg also takes customer support very seriously, and this extends to fair Limited Warranty terms and procedures across our full product range. Stromberg warrants this new product to be free from defects in operation for ninety (90) days from the date of original purchase by the original purchaser.

To claim under this Limited Warranty, PLEASE CONTACT US FIRST! If you email us at **warranty@stromberg-97.com** with a clear description of the problem and evidence of the dated purchase receipt, most issues are simple and can be addressed quickly with email advice. Terms & Exclusions apply. For full details, please visit our website.

**NOTES:**

---

---

---

---

---

---

---

---

---

---

---

---

---

---

---

---

---

---

---

---

---

---

---

---

If you need further information or assistance, please contact your Stromberg dealer, or e-mail us direct at:

**tech@stromberg-97.com**

or log on to our Tech Center at: **stromberg-97.com**



SSP#9056

# READ THIS FIRST

Thank you for choosing a genuine Stromberg e-FIRE electronic distributor. Please read this guide before installing your new module, especially the Troubleshooting section, as the module is sometimes blamed when it is still working fine. The Module Testing section shows how to test it off the car.

Always check you have the correct e-FIRE module kit for your application. Different distributor models may have different mounting plates, and will be either negative or positive ground (earth). e-FIRE modules are designed to be used only with Stromberg e-FIRE distributors.

Remember, all Stromberg e-FIRE electronic distributors should be used with a 1.5 Ohm coil and no external ballast resistor. We recommend the Stromberg 9708K '44' Coil.

## WARNING!

Correct e-FIRE electronic ignition module kit installation is critical to engine performance. Stromberg recommends installation by a professional auto electrician. An improperly installed module can cause poor engine performance or damage. Always remove the distributor cap, disconnect all electrical wiring and remove the distributor from the vehicle before starting any work - including installation of this new e-FIRE module. Failure to do so may produce sparks, causing a fire or explosion, resulting in property damage, serious personal injury or death.

## TWOSTEP INSTALLATION

### Step 1 - Remove old e-FIRE module

- A)** Take the cap off the distributor leaving the plug wires in place and disconnect all wiring (noting where each wire goes). On front-mount, e-FIRE 11A/21A/52A models it is easier to swap modules with the distributor off the vehicle. On others, you may be able to leave it in place, though if you remove it, make a note or mark where the rotor points BEFORE removing the distributor from the engine. THIS IS VERY IMPORTANT! Take a photo!
- B)** Remove the rotor arm and the black trigger ring (plus the small black plastic rotor spacer if your e-FIRE distributor has one).
- C)** Trim off the old wiring connectors and pull the module wires out through the rubber sleeve. This is easier if you remove the rubber sleeve from the body.

### Step 2 - Install new e-FIRE module

- A)** Swap in the new adapter plate with the module attached. Adjust the adapter plate so the screws are in the middle of the slot adjustment and tighten the two mounting screws. Capture the wires with the black C-clip fixed to the screw nearest the rubber wiring sleeve.
- B)** Run the new e-FIRE module wires through the rubber protective sleeve. Slip the wires through the hole in the distributor body (from inside to out) then pull the rubber sleeve into the hole. Leave a little wire slack inside the distributor body to allow for timing adjustment.
- C)** Push the black trigger ring back onto the aluminum cam adding the small plastic rotor spacer (if your distributor had one) BETWEEN the trigger ring and rotor. Replace the rotor.
- D)** Turn the distributor drive by hand checking you have a clear, but minimum, air gap between the trigger ring and the red e-FIRE module. You can adjust it by loosening the adaptor plate screws. Close (without touching) is best. Tighten both screws.

- E)** Mount the distributor back onto the engine, connecting the two wires as per your original installation. If you are unsure, you can download the complete original Owner's Manual from the Stromberg Tech Center at [www.stromberg-97.com](http://www.stromberg-97.com). New wire connectors are supplied. Now fit the distributor cap.

### Check Engine Timing

Due to slight variation in the position of the sensor within the module housing, you may need to adjust the static (idle) timing for your engine. On front-mount, e-FIRE 11A/21A/52A models (which spin counter-clockwise), move the timing screw on the side of the body clockwise (downwards) to advance or counter-clockwise to retard. If that does not provide enough adjustment, the module adapter plate allows further movement. The adjustment is sensitive. Each mark on the adjustment plate will change the timing 4 degrees at the crankshaft. Timing on other e-FIRE distributor models is adjusted by turning the whole distributor, though advance and retard will depend on which direction the rotor spins.

## WARNING!

Always stop the engine before adjusting distributor timing. Failure to do so may result in property damage, severe personal injury or death.

### Troubleshooting

Every new e-FIRE electronic ignition module is factory-tested before shipping. So if, after installation, the engine will not start, runs unevenly or simply sounds wrong, check all wiring connections first, including plug wires and all grounds. It may even show that the module was not the initial problem. Check you have the correct 1.5 Ohm coil and that the battery is fully charged. Any electronic distributor will struggle without a reliable power source. This is especially important on 6 volt models with older, resistant wiring. You need a strong 6 volts when cranking the starter. Remember, too, that the module is a switch for the coil. It does not govern spark strength.